

Intrinsically Safe Anemometer

Precision wind measurement for hazardous areas

WindObserver IS is designed to provide high accuracy wind speed and direction measurement in hazardous environments. WindObserver IS is certified as 'intrinsically safe' for use in the 'hazardous area', whilst the associated power and communications interface is located in the 'non-hazardous area'.

The ATEX, IECEx & UKEX certification ensures that the wind system may be deployed over a large geographical area. The system requires no regular maintenance, beyond a visual check, eliminating in-service maintenance costs in the offshore environment where the installation of reliable low maintenance equipment is essential.

Customer selectable vector rolling average and 3 second gust in accordance with WMO guidelines.

Typical applications

- Offshore oil production and drilling platforms.
- Support tankers.
- Onshore petrochemical plants.
- Helidecks in hazardous environments.
- Paint spray booths.

WindObserver IS key features

- Intrinsically safe: ATEX, IECEx & UKEX certification.
- Low voltage or optional mains power supply.
- Galvanic isolation.
- ASCII or NMEA serial output.
- 0-75m/s wind speed operation.
- Averaging/gusts to WMO guidelines.
- Tested for exposed environments (IP66, BS EN 60945).
- Low maintenance requirements.

Benefits

- Precision wind speed and direction measurement in hazardous environments.
- Reduced offshore maintenance costs.
- Easy to install and long operational life.
- Proven service internationally.



WindObserver IS intrinsically safe anemometer.



WindObserver IS is designed for use in potentially explosive atmospheres.

Intrinsically Safe Anemometer

Precision wind measurement for hazardous areas

HAZARDOUS AREA



WindObserver IS
Intrinsically safe
ultrasonic anemometer

NON-HAZARDOUS AREA



Low Voltage (DC)
Power & Commu-
nications Interface (LVPCI)

(Mains power adaptor option also available - see page 5)

ATEX and IECEx certification is valid for systems that include the WindObserver IS with a Gill Power & Communications Interface only.

WindObserver IS ultrasonic anemometer for use in hazardous areas

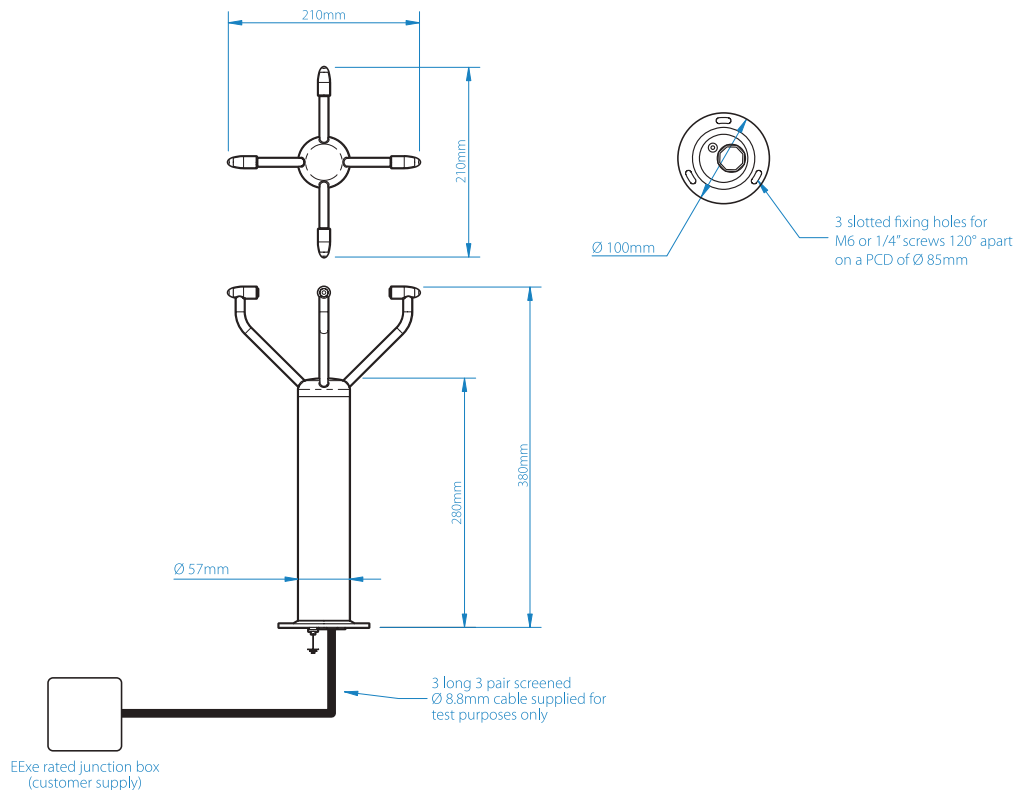

Intrinsically Safe Anemometer

Precision wind measurement for hazardous areas

WIND SPEED	
Range	0-75 m/s
Starting threshold	0.01 m/s
Accuracy	12 m/s 2% RMSE
Resolution	0.01 m/s
Units of measurement	m/s, km/h, mph, kts, ft/min

WIND DIRECTION	
Range	0-360°
Accuracy	±4° RMSE
Resolution	1°
Units of measurement	degrees

MEASUREMENT	
Data output rates	1 Hz, 2 Hz or 4 Hz
Parameters	UV and polar
Units	m/s, km/h, mph, kts, ft/min
Averaging	0 - 3600 s

OUTPUTS	
Digital comms modes??	RS422, full duplex to LVPCI
Baud rates	1200, 2400, 4800, 9600, 19200
Formats	8 bit data, odd, even or no parity
Protocols	ASCII, NMEA 0183
Anemometer status	Supplied as part of standard Gill message (NMEA output includes V and A codes as part of the message)

POWER SUPPLY	
Anemometer	6-12 VDC, 30 mA peak (from LVPCI) All circuits protected to 0.8 joules

MECHANICAL	
Construction	Stainless steel 316
Weight	1.9 kg
Size	380 mm x 210 mm

ENVIRONMENTAL	
Moisture protection	IP66
Operating temp.	-30°C to +70°C
Storage temp.	-50°C to +75°C
Humidity	0% to 100% RH
Precipitation	300 mm/hr

CERTIFICATIONS & APPROVALS	
Intrinsic safety	ATEX, IECEx & UKEX certification. Certificates available to view in full on gillinstruments.com

Intrinsically Safe Anemometer

Precision wind measurement for hazardous areas

Low Voltage Power & Communications Interface (LVPCI) for use in non-hazardous areas

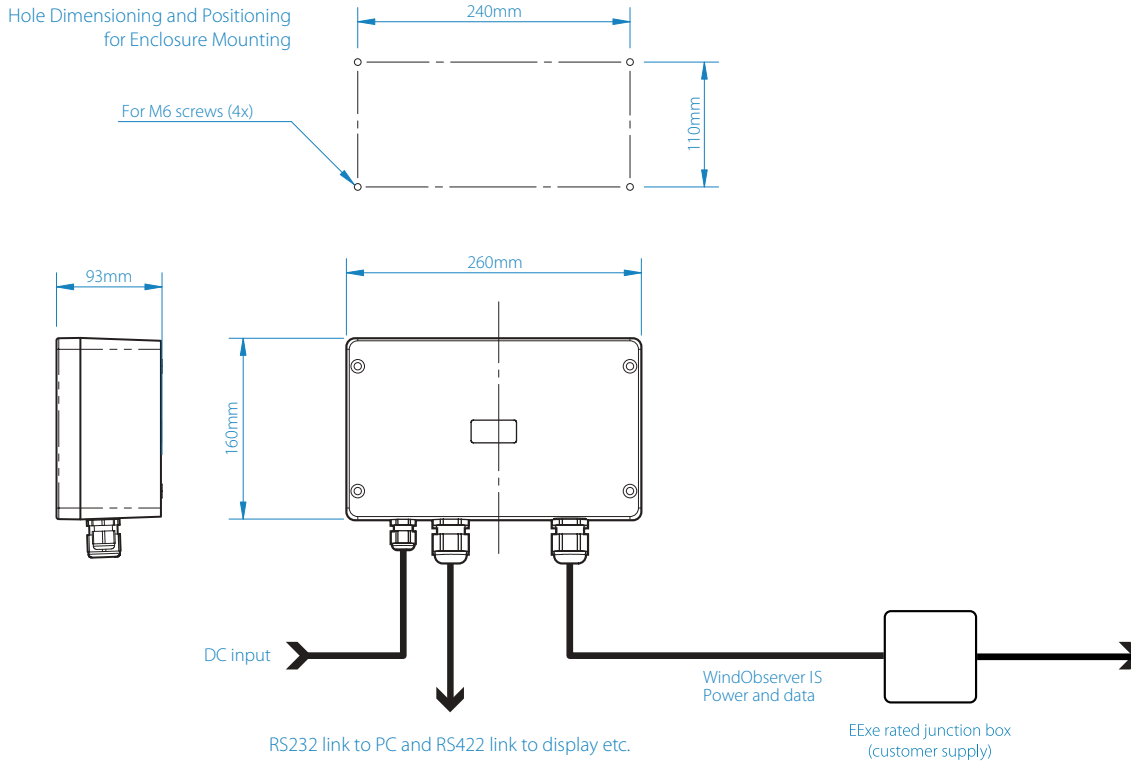

CERTIFICATIONS & APPROVALS

Intrinsic safety	ATEX, IECEx & UKEX certification. Certificates available to view in full on gillinstruments.com
------------------	--

INPUTS AND OUTPUTS

Digital input	RS422 (data from WindObserver IS to LVPCI)
	Data lines between the anemometer and power supply opto-isolated and protected with zener barriers
Digital output	RS232 and RS422 (data from LVPCI)

LVPCI POWER INPUT

Power requirement	DC supply
Input power	9-30 VDC at 200 mA max
	Galvanic isolation between input power and WindObserver IS
	No external earth required
Output power	10.5 VDC at 50 mA to WindObserver IS (fused 100 mA)

MECHANICAL

External construction	Fibox Euronord polyester
Weight	2.4 kg
Size	260 x 160 x 93mm
	Refer to additional information drawing on datasheet or manual

ENVIRONMENTAL

Moisture protection	IP54
Operating temp.	-30°C to +60°C
Storage temp.	-50°C to +75°C
Humidity	5% to 90% RH
EMC	EN 61326-2-1:2013, EN 61204-3:2000, EN 60945:2002 clause 9 & 10

Intrinsically Safe Anemometer

Precision wind measurement for hazardous areas

Mains power adaptor (5319-10-005) technical specification

POWER REQUIREMENT	
Input voltage	90-264 VAC
Output voltage	24 VDC
Unit power consumption (no load input power)	75 mW
Input power over voltage protection limit	not present
Input power reverse-polarity protection limit	N/A
Input power protection duration limit	internal T1.0A/250 VAC fuse

ENVIRONMENTAL	
Moisture protection	IP20
Operating temp.	0°C to +60°C
Storage temp.	-40°C to +85°C
Humidity	5% to 95% RH
EMC	EN 61000-6-3:2007 EN 61000-6-1:2007

For more information about WindObserver IS, please contact Gill Instruments.

Designed and manufactured in the UK by Gill Instruments Limited.