

Monitors visibility and obstruction to vision caused by dust, fog, rain, drizzle, snow and hail

Designed for easy integration with intelligent systems such as weather stations and aviation applications

KEY FEATURES & BENEFITS

- 10m to 40km measurement range
- Selectable measurement resolution of 1m or 10m (default)
- Compact forward scatter design
- Not affected by local lights
- Easily installed by one person
- Hood heating for use in extreme environments
- Easy integration of Biral ALS-2 ambient light sensor
- Comprehensive self-test and maintenance data
- 3 Years warranty

The SWS-050 is optimised for use in applications where accurate and reliable visibility measurements are required. The forward scatter measurement principle and compact design ensure the output is both accurate and reliable in all weather conditions. The inclusion of hood heating and advanced self-test features as standard makes the SWS-050 Biral's most cost effective solution for visibility measurement.

Visibility Measurement

The measurement of visibility by forward scatter as used by the SWS-050 is now widely accepted and seen as having significant advantages over more traditional techniques such as the use of transmissometers or backscatter sensors. Backscatter sensors share the SWS-050's advantage of being compact however the backscatter signal is strongly dependent on the type of obstruction to vision resulting in poor accuracy and limited upper range. Transmissometers were once considered the standard method for visibility measurement due to their direct measurement of visibility however, their limited measurement range, high cost of acquisition, large size and significant maintenance costs have resulted in their use being limited to a few specialist applications. The SWS-050 by contrast is compact, requires little maintenance and has a visibility range of 10m to 40km, whilst its measurement performance is proven to be comparable to that of a transmissometer. The calibration of the SWS sensor family was undertaken in accordance with the recommendations of ICAO 9328 and is traceable to a national weather service transmissometer.

The standard data message reports both averaged Meteorological Optical Range (MOR) with a fixed measurement

range of 10m to 40km, and atmospheric Extinction Coefficient (EXCO). The features, accuracy and resolution of the SWS-050 ensure it complies with ICAO and WMO specifications for aviation use including use in instrumented Runway Visual Range (RVR) systems.



Designed for aviation, roads, research and general meteorological use.

Applications

The SWS-050 is a very capable well specified general purpose visibility sensor that is used in a wide variety of applications and operating environments. With the same accuracy and reliability as other members of the SWS sensor series the ICAO 9328 compliant design and seamless integration with the ALS-2 Ambient Light Sensor allow the SWS-050 to be used for both general visibility monitoring and as part of instrumented RVR systems.

The 10m to 40km measurement range coupled with advanced self-test make the sensor well suited for weather station use. Window contamination monitoring and compensation ensure the results remain accurate even in challenging conditions. Where blowing snow is experienced the hood heaters, which are fitted as standard to the SWS-050, keep the optics clear and the sensor functioning correctly.

Interfacing and Connectivity

Like all SWS series sensors the SWS-050 is designed to be easy to use, with the ASCII text data message transmitted at user defined time periods or in response to a polled request using a RS232, RS422 or RS485 interface. The standard data message provides averaged MOR however the user can select an EXCO output if preferred. The only option available for the SWS-050 is an interface to the ALS-2 Ambient Light Sensor for use in



aviation applications where RVR information is required. The ALS-2 Ambient Light Sensor data is appended to the standard sensor data message simplifying both the installation and data processing.

Maintenance and Cost of Ownership

To keep track of the operational status of the sensor, abbreviated self-test information is included in every data message with a full self-test report available on request. The SWS-050 has a series of features that reduce maintenance requirements to a minimum whilst ensuring accurate and reliable operation. These features include contamination monitoring on all windows which automatically corrects the output data and provides two stage warnings allowing maintenance to be performed as efficiently as possible. Calibration checks and recalibration are simple and quickly accomplished in the field by a single person. The need for such procedures is limited however as the stability of the light source and receiver circuitry is such that recalibration intervals are typically measured in years.

The SWS-050 is DC powered with the capability to accept separate supplies for sensor electronics and the high power hood heaters. Hood heating is only required in regions where blowing snow is encountered and to conserve power the heaters activate at 2°C and switch off at 4°C.

Advanced Functional Test Mode

All Biral visibility and present weather sensors have the capability to temporarily output specific data via a test mode. In this mode the user can define visibility, window contamination and fault conditions for a pre-determined time period. This functionality is useful during Factory or Site Acceptance Testing (FAT or SAT), or system integration to test downstream processing of the output data.

Sensor Configuration Information

For a detailed explanation of the configuration options please refer to the table below.

SWS-050 Sensor

Housing:

- 05** – Powder paint coated aluminium (standard)
- 05A** – Hard coat anodized, powder coated

Hood Heating:

- HV** – With heating

Data Output:

- J** – Standard outputs

Self-Test and Monitoring:

- A** – Advanced self-test and monitoring

Ambient Light Sensor Interface (ALS-2):

- NA** – Without ALS-2 Interface
- WA** – With ALS-2 Interface

Configuration:

- RC** – Regular configuration
- SC** – Special configuration



Example: **05A.HV.J.A.NA.RC** (Please use this code when ordering your sensor).

Configuration Options Explained

Option	Description
Housing Options	The sensor enclosure is aluminium, it is corrosion protected using either a chemical conversion coat with a powder coat paint finish or hard coat anodizing and a powder coat paint finish. The hard coat anodized with paint finish is recommended for offshore and marine environments. Option 05 : Powder coated aluminium (standard) Option 05A : Hard coat anodized, powder coated
Heating Options	Heated hoods are available to stop snow from accumulating around the optical window. The hood heating option is only required in regions where snow is experienced. Option HV : Hood heating included
Data Output	The sensor has RS232, RS422 AND RS485 serial output capabilities. Both MOR and EXCO are available in the serial data output. No other options available. Option J : Standard outputs (RS232 and RS422/RS485)
Self-Test & Monitoring	The sensor is provided with Advanced Self-Test capability. Advanced self-test capability provides monitoring of all the essential sensor functions, including contamination of the transmitter and receiver windows, plus receiver sensitivity monitoring. Advanced self-test capability provides greater measurement confidence in applications where different levels of contamination may occur on the sensor windows, for example where strong or gusty winds are experienced. No other options are available. Option A : Advanced Self-Test
ALS-2 Interface	The sensor may be configured to allow direct connection of the ALS-2 Ambient Light Sensor. The Ambient Light Sensor is typically used in airport applications where Runway Visual Range (RVR) must be calculated. Option NA : Without Ambient Light Sensor Interface Option WA : With Ambient Light Sensor Interface
Configuration	Reserved for customer specific configurations. Option RC : No customer specific configuration Option SC : Special customer specific configuration

SWS-050

Visibility Sensor Specifications



Visibility Measurement

Measures	Visibility (MOR & EXCO)	
Output	Serial data	
Range (visibility)	10m to 40km	
Measurement Error	≤4.2% at 600m ≤6.8% at 5km ≤12.3% at 15km ≤17.1% at 25km	≤5.1% at 2km ≤9.6% at 10km ≤14.8% at 20km ≤19.4% at 30km
Measurement resolution	1m or 10m (default)	
Measurement principle	Forward scatter meter with 39° to 51° angle, centred at 45°	

Outputs and Reports

Output rate (seconds)	10 to 300 (selectable)
Serial outputs	RS232, RS422 and RS485

Power Requirements

Sensor Power	9-36Vdc
Hood heating power	24Vac or dc
Basic sensor	3.5W
Window heaters	1.7W
Hood heaters	24W

Additional Features

Hood heaters	Fitted as standard
Window contamination monitoring	Fitted as standard to both sensor head windows

Environmental

Operating temperature	-40°C to +60°C
Operating humidity	0 – 100% RH
Protection rating	IP66/IP67

Certification & Compliance

CE Certified
EMC compliance with EN61326-1997, 1998, 2001
RoHS and WEEE compliant

Physical

Material	Aluminium. Powder paint finish, with optional hard anodize base layer.
Weight (incl. mounting kit)	4.3kg
Length	811mm
Warranty	3 years
Lifetime	>10 years

Maintenance

Self-test capability	As standard
User confidence check	6 months recommended
Window Cleaning	Automatic compensation and warnings
Field calibration	With optional calibration kit

Included with Sensor

The sensor is delivered in sturdy recyclable foam filled packaging with:	
- Pole mounting kit (2 x U-bolt)	
- User manual and calibration certificates	

Accessories – Optional

00.SWS.CABLE-D	SWS Series Data Cable per metre
00.SWS.CABLE-P	SWS Series Power Cable per metre
SWS.CAL	SWS Series Calibration Kit
SWS.CASE	SWS Series Transit Case
SWS.SK.100	SWS Series Spares Kit
SWS.WTY100	1 Year extended warranty
PW.MAINS	Mains Power Adaptor

Specifications are subject to review and change without notice. E&OE.

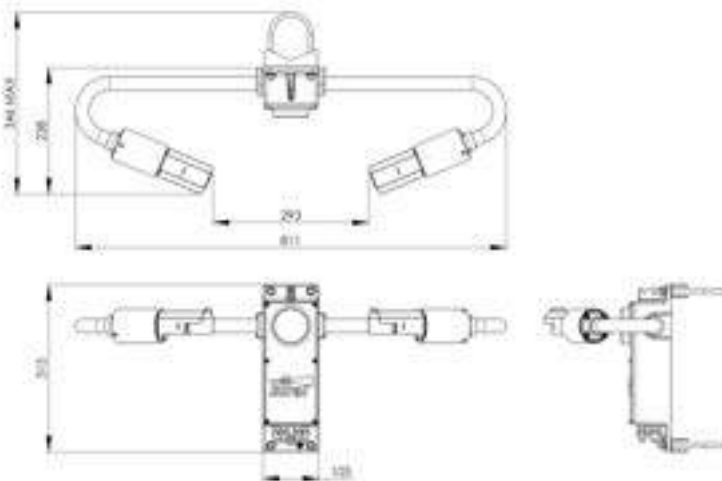

Dimensions in mm